

AG-04
6.3% t
1.7% c

AG-09
4.8% t
2.0% c

HT-05
4.8% t
0.0% c

2 HS50 servo 12.0 g
Hitec 555 RX 15.0 g
3 NiCd 120mAh 18.0 g
Wiring 2.0 g

Wing 55.0 g
Fuse 8.0 g
Boom 3.0 g
Tail 5.0 g
Rods 1.0 g

TOTAL 119.0 g

V = 5 - 12 m/s
= 10 - 28 mph
Re = 8 - 23K /in

CL = 0.8 - 0.1
L/D = 17 - 8

Spyder Foam
1 layer 0.75 oz glass,
+/-20 deg front
+/-45 deg elevator

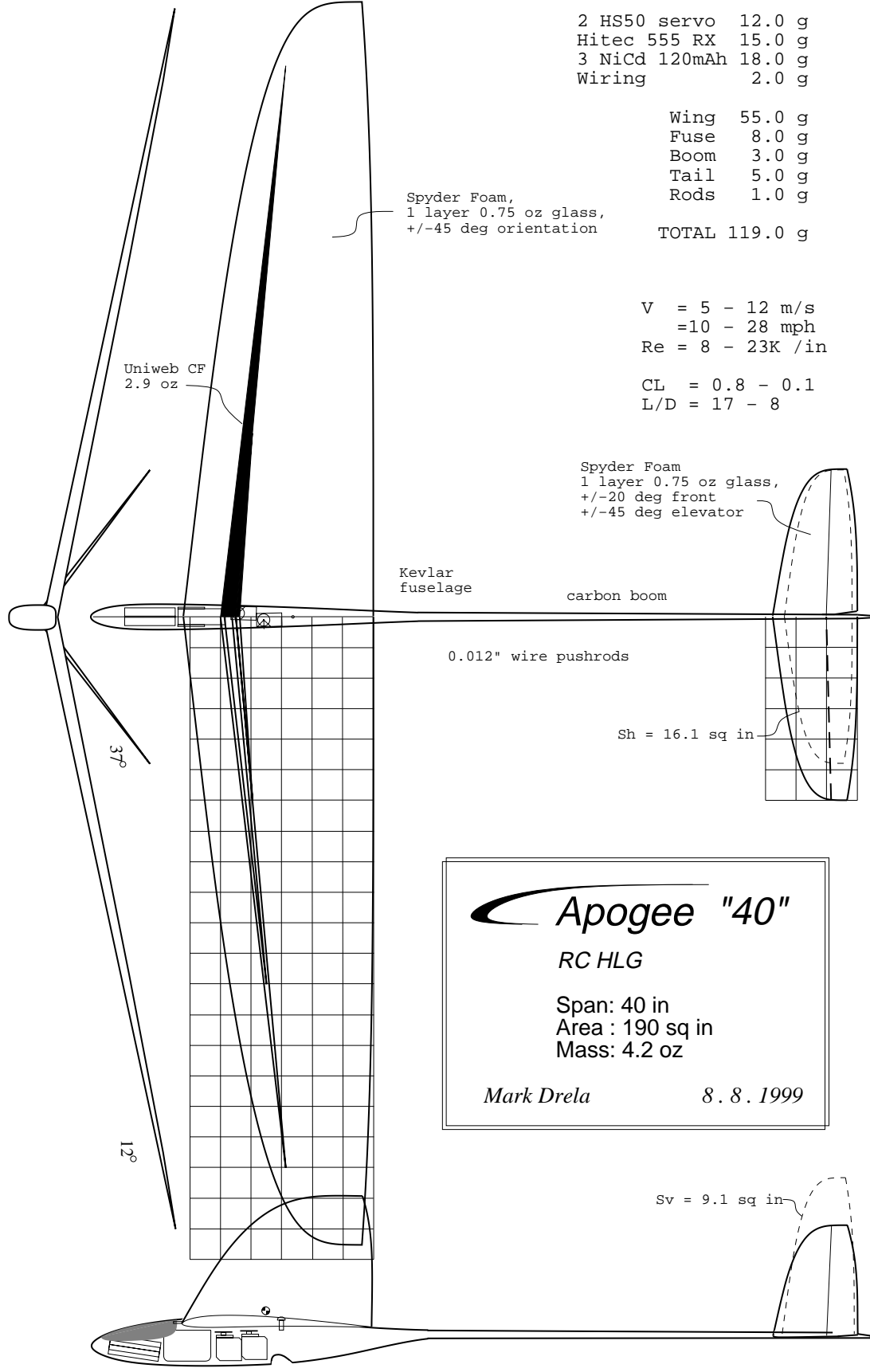

Apogee "40"

RC HLG

Span: 40 in
Area : 190 sq in
Mass: 4.2 oz

Mark Drela 8.8.1999

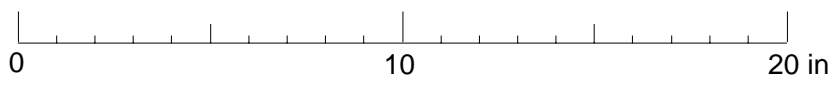

0.48" +/-27 deg max throw before mixing