

Allegro V-mount (homemade versions)

M.Drela 01.12.01

Design loads: 10 lb on bolt
10 oz on horn

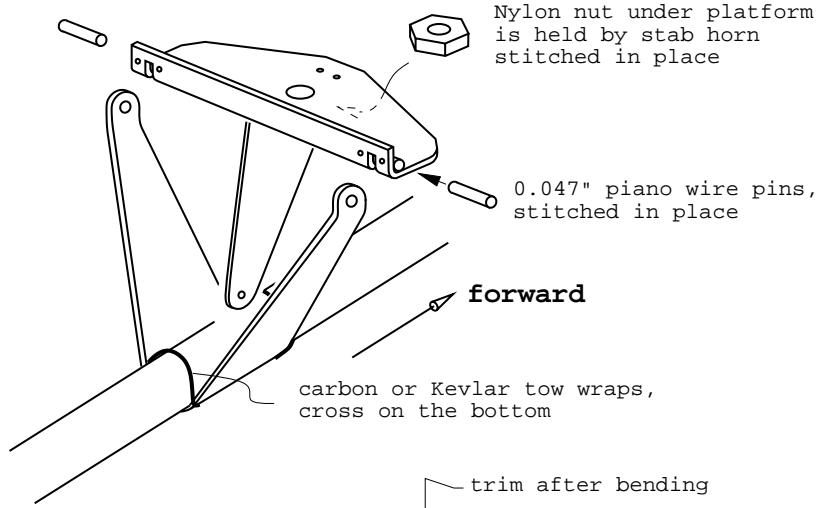

Aluminum Version (2.5g)

(Full size patterns)

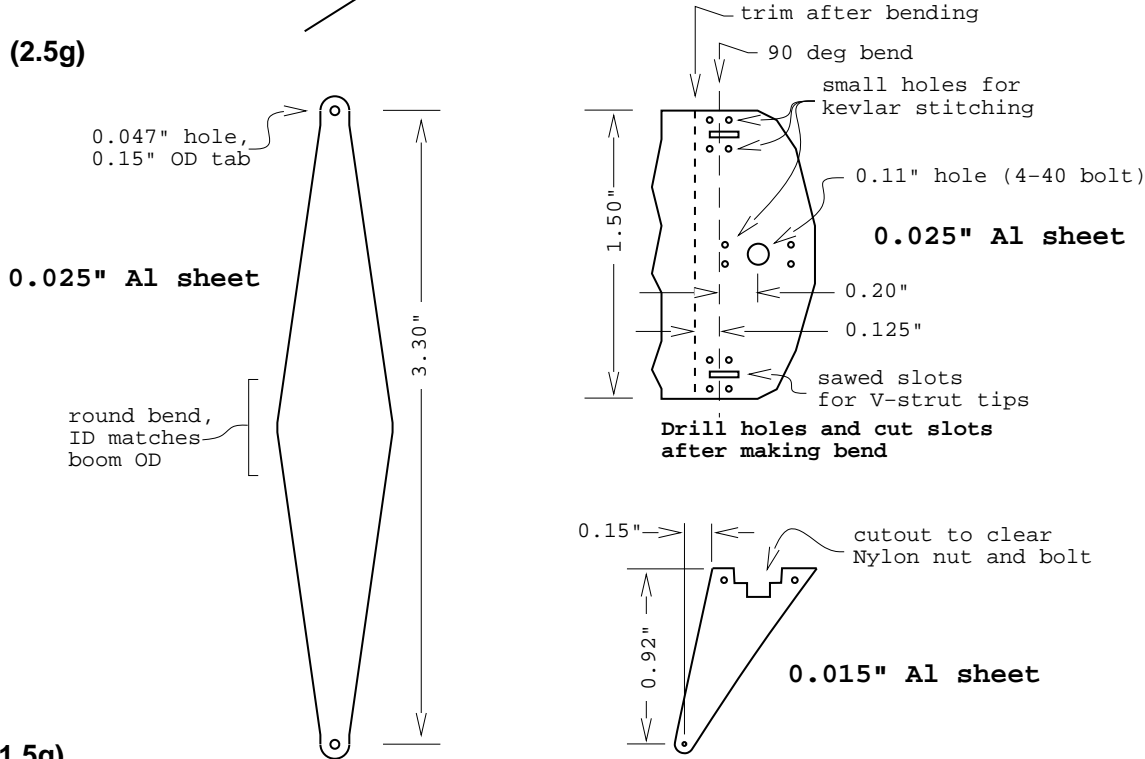

Carbon Version (1.5g)

two wraps of 3k carbon tow between cloth layers

wood forms, covered with shiny tape, waxed

0.047" wire pins (make shorter if vacuum bagging)

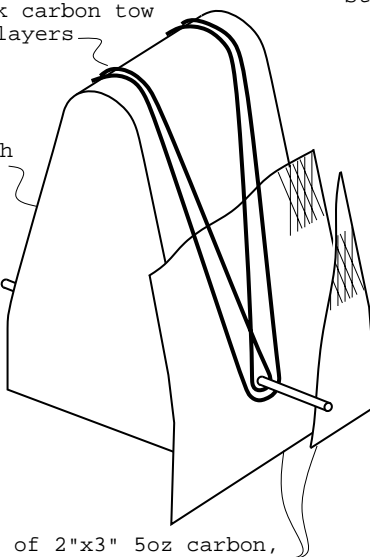

two layers of 2"x3" 5oz carbon, +/-45 sheared to +/-20 or less.

Stab horn...

Laminated from two layers 5 oz carbon, +/-20. Poke with wire to form pushrod hole (better than drilling). Roughen and attach to platform with 0.75oz glass fillets while platform epoxy is still green (see below)

three layers of 1.5"x1.5" 5oz carbon +/-45 sheared to +/-20 or less.

